

Specifications

MODEL		TZ™-50	
MEASUREMENTS		US	Metric
Working height*		55 ft 6 in	17.09 m
Platform height		49 ft 6 in	15.09 m
Entry height - extended		1 ft 8 in	.51 m
Horizontal reach		29 ft 2 in	8.89 m
Clear outreach		23 ft 1 in	7.04 m
Up and over clearance		22 ft	6.71 m
A Platform length		2 ft 2.8 in	.68 m
B Platform width		3 ft 8 in	1.12 m
C Height - stowed		6 ft 10 in	2 m
D Length - stowed		23 ft 6 in	7.16 m
E Width - stowed		5 ft 6 in	1.68 m
F Ground clearance - center		10 in	.25 m
G Length - outrigger footprint		14 ft 4 in	4.37 m
H Width - outrigger footprint		14 ft 4 in	4.37 m

PRODUCTIVITY			
Lift capacity (ANSI, CSA) - standard		500 lbs	227 kg
Lift capacity (ANSI, CSA) - rotating platform		500 lbs	227 kg
Lift capacity (CE) - standard		440 lbs	200 kg
Lift capacity (CE) - rotating platform		440 lbs	200 kg
Jib boom		4 ft 1 in	1.25 m
Jib working range		135°	
Self leveling platform		2.5° standard	
Platform rotation option		160° hydraulic	
AC power to platform		standard	
Turntable rotation		359° non-continuous	
Outrigger leveling capability		10°	
Drive speed		0.85 mph	1.37 km/h
Gradeability**		20%	
Towing speed rate		60 mph	97 km/h
Tongue weight - ANSI, CSA		400 lbs	181 kg
Surge and parking brakes		standard	
Controls		variable speed system	
Tires - ANSI, CSA		ST 225/75 R15	
Tires - CE		215 R14C	
Coupler		2 in (5.08 cm) hitch coupler standard	

POWER			
Power source - standard		24 V DC (four 6 V 225 Ah batteries)	
Power source - drive option		24 V DC (four 6 V 244 Ah batteries)	
Power source - option		Hybrid DC/Gas Honda 5.5 hp (4.1 kW)	
Fuel tank capacity		.95 gal	3.6 L
Hydraulic tank capacity		4.75 gal	18 L
Hydraulic system capacity		8.0 gal	30 L

WEIGHT***			
ANSI, CSA, CE		4,400 lbs	1,996 kg
CE		4,464 lbs	2,025 kg

STANDARDS COMPLIANCE ANSI A92.2, CSA C225, CE Compliance, AS 1418.10

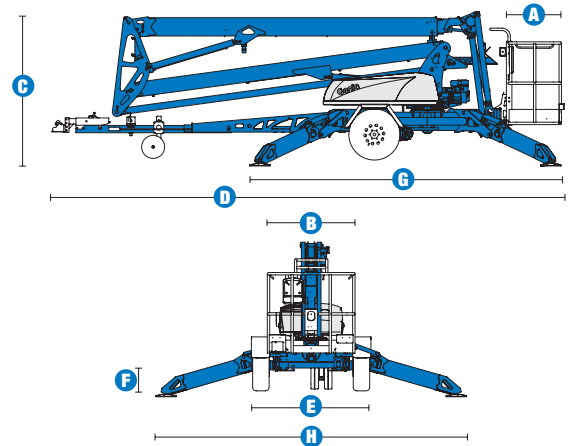

RANGE OF MOTION TZ™-50

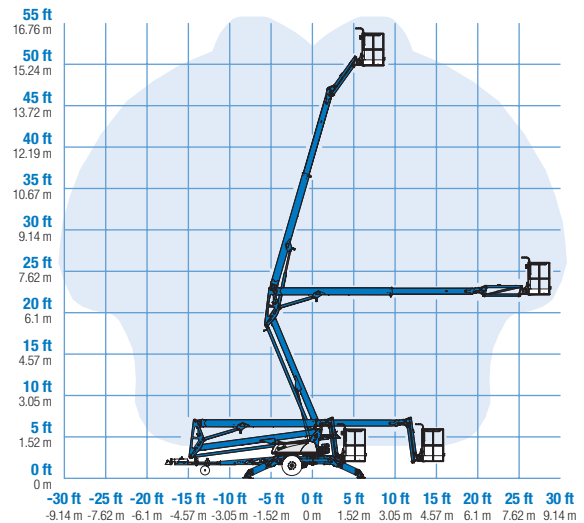

* The metric equivalent of working height adds 2 m to platform height. U.S. adds 6 ft to platform height.

** Gradeability applies to driving on slopes. See operator's manual for details regarding slope ratings.

*** Weight will vary depending on options and/or country standards.

Features

EASILY CONFIGURED TO MEET YOUR NEEDS

PLATFORM OPTIONS

- Aluminum 26.8 x 44 in (.68 x 1.12 m) platform
- Platform overload option
- 160° hydraulic platform rotation

POWER OPTIONS

- 24 V DC power source
- Hybrid DC/Gas

DRIVE

- Drive and set option

COUPLER OPTIONS

- Combination hitch
- 2 in (5.08 cm) ball coupler
- 2.31 in (5.87 cm) ball coupler
- 2.5 in (6.53 cm) I.D. pintle ring coupler
- Clevis coupler

TIRE OPTIONS

- ST 225/75 R15 tires (ANSI, CSA)
- 215 R14C tires (CE)

STANDARD FEATURES

MEASUREMENTS

- 55 ft 6 in (17.09 m) working height
- 29 ft 2 in (8.89 m) horizontal reach
- Up to 500 lb (227 kg) lift capacity

PRODUCTIVITY

- Industry leading working envelope
- Extension boom
- Self-leveling platform
- Variable speed control system
- Auxiliary pump down
- AC power to platform
- Automatic leveling system
- Tilt alarm / sensor
- Hydraulic outriggers
- Outrigger interlocks and indicator
- 359° non-continuous turntable rotation
- Hour meter
- Surge brakes
- Parking brake
- Combination hitch with coupler level lock
- Dual jockey wheels
- Easy to access batteries

POWER

- 24 V DC power source



OPTIONS & ACCESSORIES

PRODUCTIVITY

- Platform overload system
- 160° hydraulic platform rotation
- Tool tray
- Fluorescent tube caddy
- Operational warning light package
- Ladder option
- Non-marking outrigger footpads
- Spare tire
- Wheel chocks
- 2 in (5.08 cm) ball coupler
- 2.31 in (5.87 cm) ball coupler
- 2.5 in (6.53 cm) I.D. pintle ring coupler
- Clevis coupler
- Combination hitch
- Drive and set option with larger battery
- Battery charge indicator (BCI)

POWER

- Hybrid DC/gas option

Genie United States

18340 NE 76th Street
P.O. Box 97030
Redmond, Washington 98073-9730

Telephone **(425) 881-1800**
Toll Free in USA/Canada **800-536-1800**
Fax (425) 883-3475

Genie Europe

The Maltings,
Wharf Road
Grantham NG31 6BH
U.K.

Telephone **+44 (0)1476 584333**
Fax +44 (0)1476 584334

Email: infoeurope@genieind.com

Distributed By:

For further information, please contact your local distributor or the Genie Industries sales office listed. Continuous improvement of our products is a Genie policy. Product specifications are subject to change without notice or obligation. The photographs and drawings in this brochure are for illustrative purposes only. Refer to the appropriate Operator's Manual for instructions on the proper use of this equipment. Failure to follow the appropriate Operator's Manual when using our equipment or to otherwise act irresponsibly may result in serious injury or death. Prices and specifications subject to change without notice. The only warranty applicable is the standard written warranty applicable to the particular product and sale. Genie makes no other warranty, expressed or implied. Products and services listed may be trademarks, service marks or trade-names of TEREX Corporation and/or its subsidiaries in the USA and other countries and all rights are reserved. Copyright © 2005 Genie Industries, Inc. "Genie" is a Registered Trademark of Genie Industries, Inc. in the USA and many other countries. Genie is a TEREX Company.